

Institutional Rocket Stove with Chimney (CIRS) Assembly Guide

Designed by: Peter Scott
February 2010

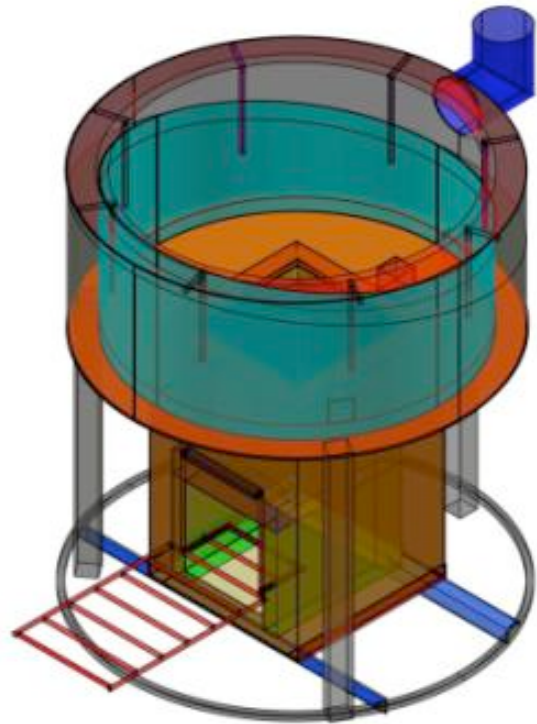

1 MEASURING POT DIMENSIONS

Accurate measurement of the exterior dimensions of the cooking pot is critical. Use a soft/ flexible measuring tape when taking measurements. Take all measurements in millimeters. Three dimensions of the pot are needed: **the outside circumference of the pot measured at the widest point, the full height of the pot (H), and the height from the bottom of the pot to the bottom of the handles (h).**



- i. Pot circumference (C) _____ mm
- ii. Full height of the Pot (H) _____ mm
- iii. Height of pot to handle (h) _____ mm



1a Combustion Chamber Liner and Insulation Thickness

Choose a combustion chamber liner and insulation thickness that is appropriate for the materials that are available in your region. In Ethiopia we use a 30 mm thick ceramic liner surrounded by 50 mm of loose pumice Insulation. The goal is to develop a liner that can withstand thermal shock and abrasion as well being insulative. See Appendix A for more details

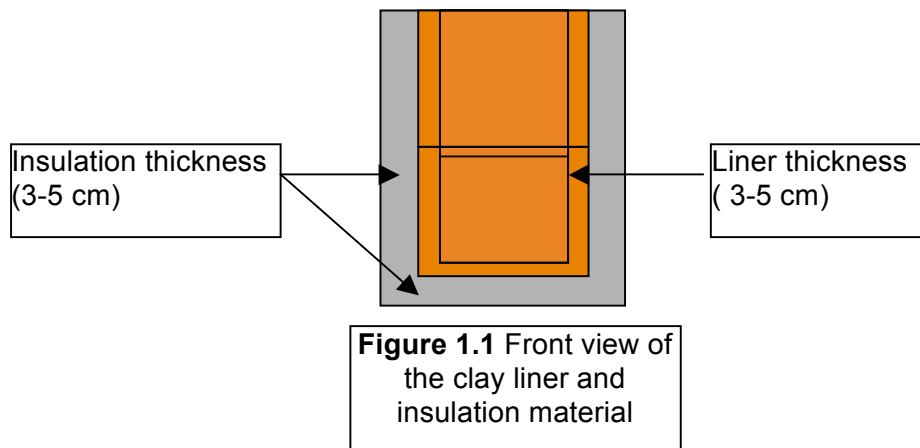

2 COMPONENTS OF CIRS (METAL)

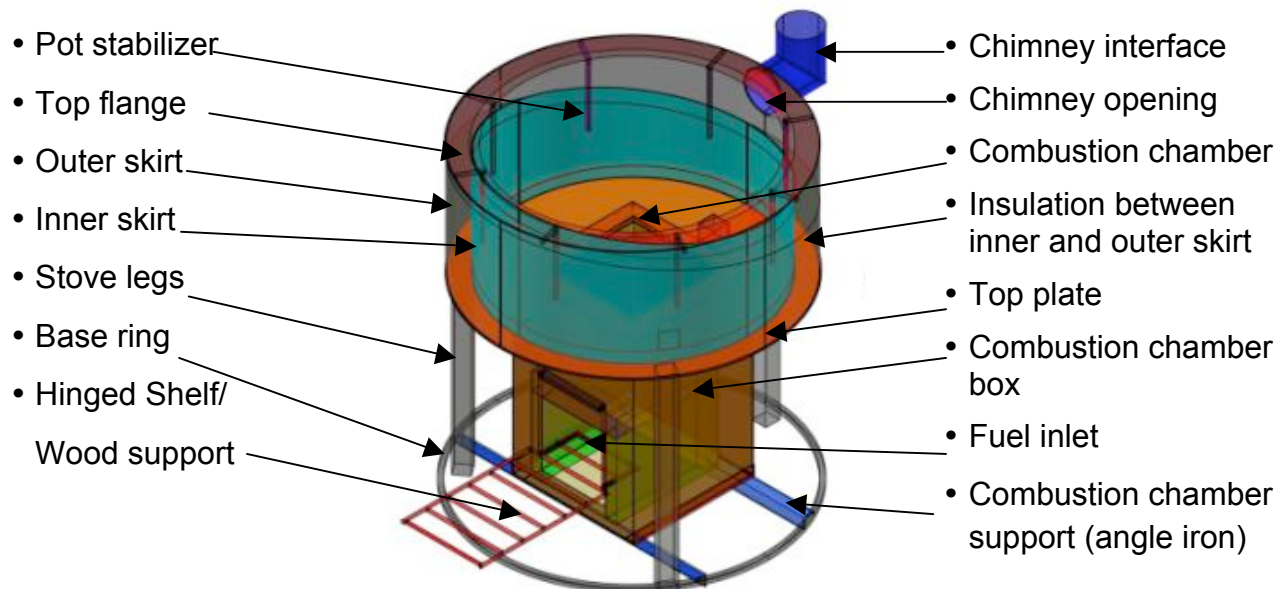

- **Chimney interface** (Use 0.8 - 1 mm mild steel sheet)
- **Round Bar:** Use 10 mm for Pot Stabilizer inside skirt
- **Sheet metal:** All sheet metal should be 1.5 mm thick
- **Legs and pot supports (not shown).** Use 40 mm wide by 1.5 – 3 mm thick square tube
- **Angle iron:** Use 30 by 30 by 3 mm thick
- **Round bar:** Use 10mm for wood support
- **Round bar:** Use 12 mm for base ring

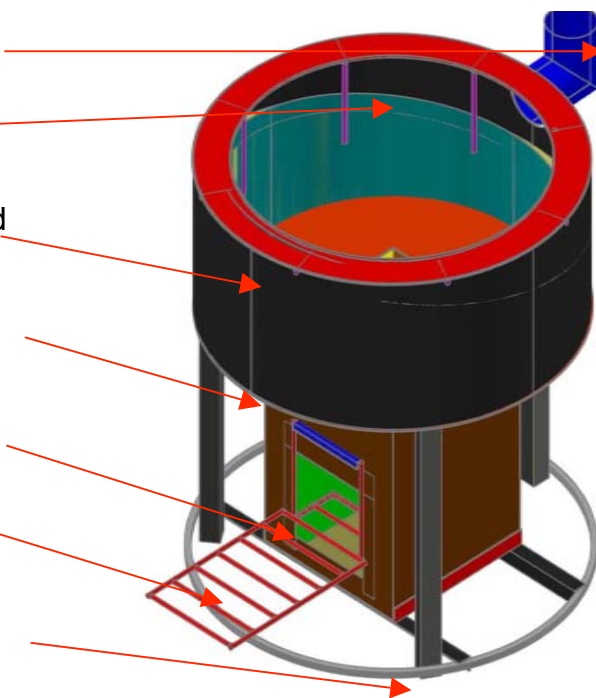

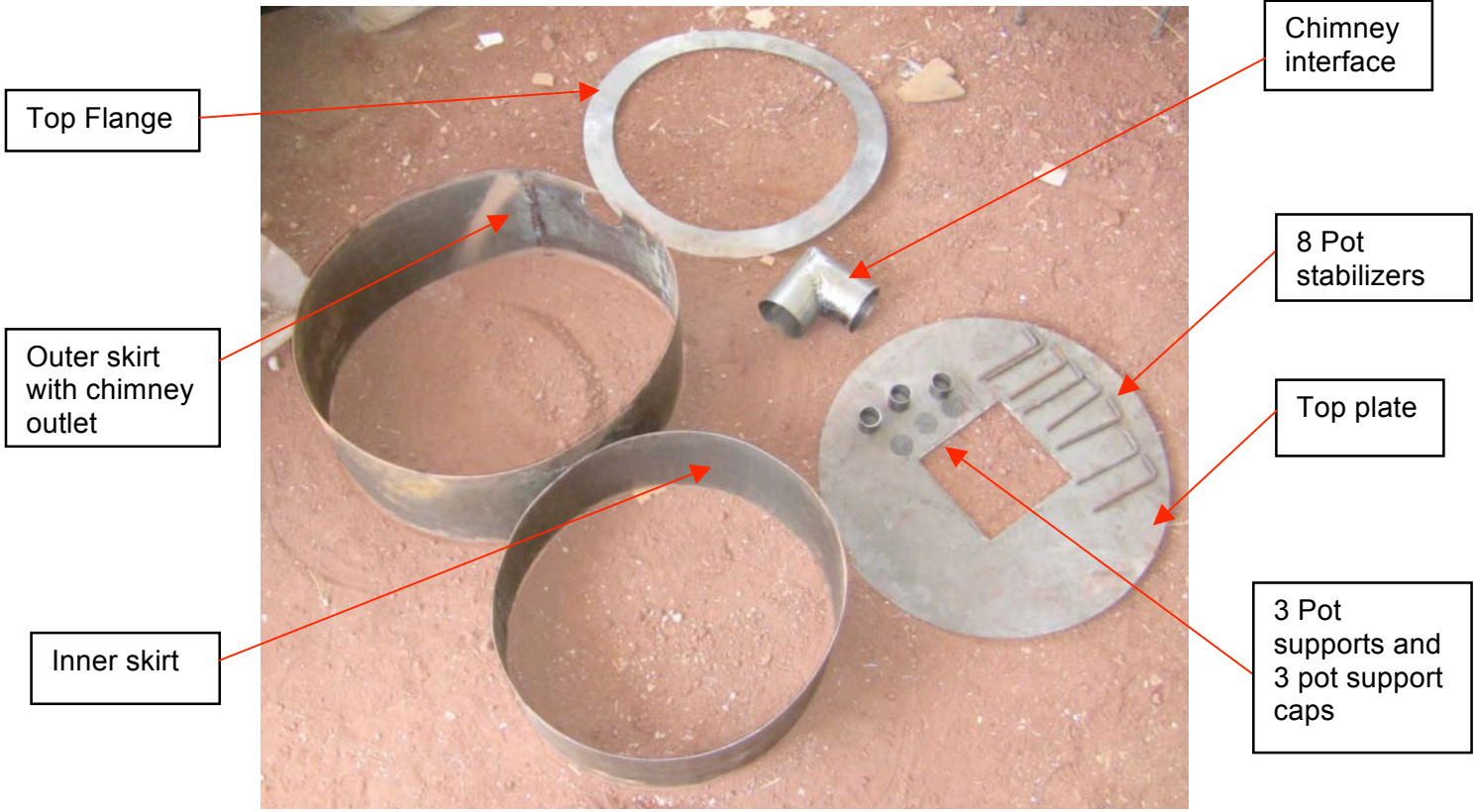

4 Combustion chamber supports (30 by 30 by 3 mm)



Combustion Chamber



3 Stove legs (40 by 40 by 3mm square tube)

Base ring

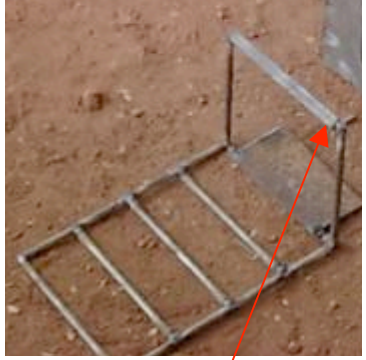

Hinged shelf

3 COMPONENTS OF CIRS (COMBUSTION CHAMBER LINER)

A number of options exists for constructing a combustion chamber. This manual utilizes ceramic tiles surrounded by insulation. Please see Appendix A for more details



4 PRODUCE THE SHEET METAL CLADDING FOR THE COMBUSTION CHAMBER

The metal box for the combustion chamber is prepared from three separate pieces of 1.5mm mild steel sheet. The two side walls and the bottom are made from a single section of sheet metal. Two separate pieces of sheet metal are used to make the front and back sections.

Figure 4.1 Pieces of sheet metal for combustion chamber cladding

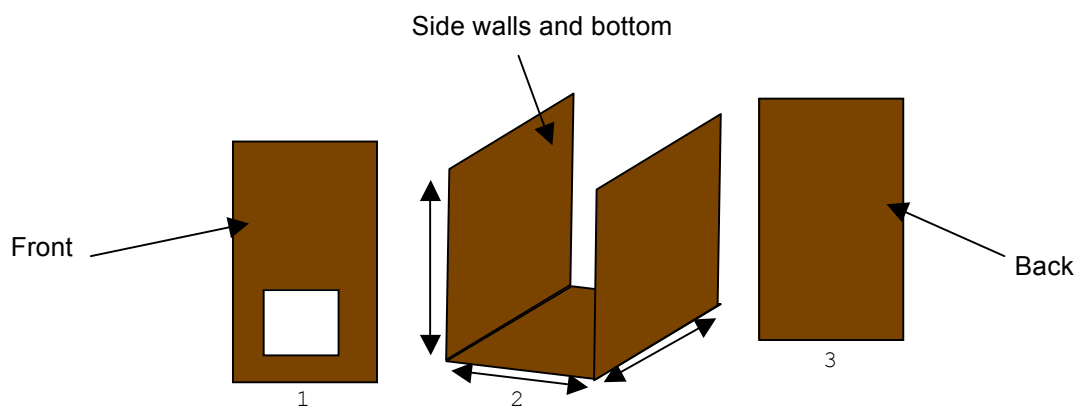

4a. Produce the bottom and two sides of the metal combustion chamber

The thickness of the clay liner and insulation (entered in the CIRS excel guide) will determine the size of the combustion chamber box dimensions.

Cut a piece of sheet metal with dimensions indicated on figure 4.2 and fold it as shown in Figure 4.2 below to make the sides and the bottom of the combustion chamber.

Figure 4.2 Fold the sheet metal to make the sides and bottom of the combustion chamber

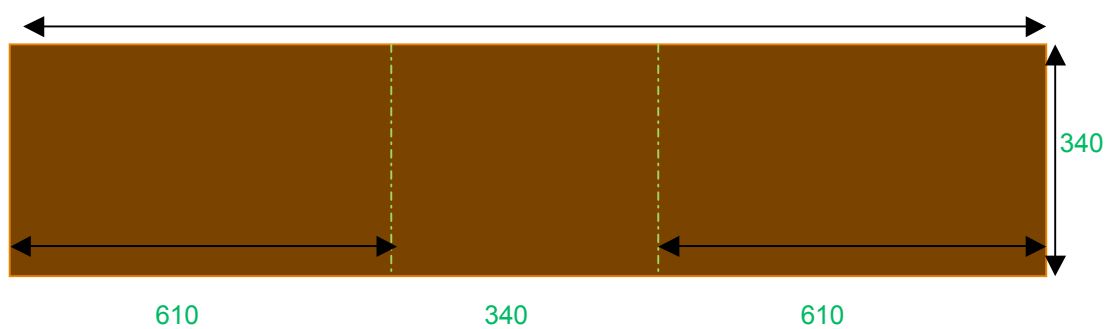

On following figures, following dimensions should be used:

F28: 610

F29: 340



4b. Produce the face plate of the metal combustion chamber

To produce the front plate of the metal combustion chamber, cut a piece of 1.5 mm mild steel with dimensions as indicated below.

The face plate and the back plate of the combustion chamber are equal except that the front plate has an opening for the fuel inlet equal to 220. The distance from the **bottom** of the face plate to the **bottom** of the fuel inlet is 58.5

Other dimensions shown on figure 4.4:

Width (F30): 337
Height (F31): 608.5
Bottom (F32): 58.5
Opening (F4): 220

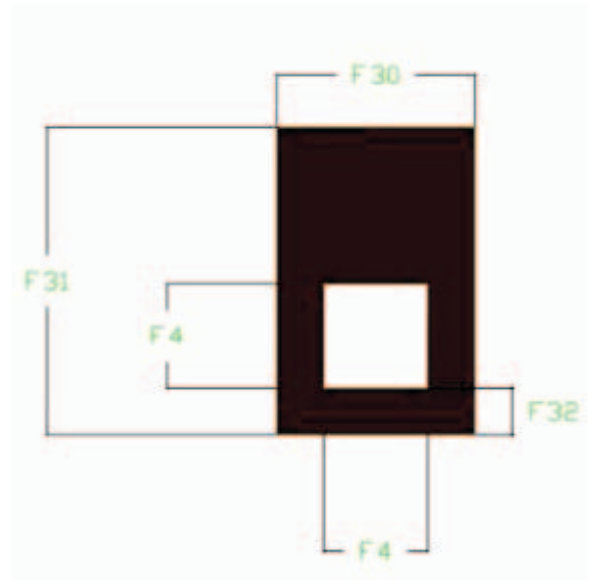

Figure 4.4: Dimension of the front plate of the combustion chamber

4c. Produce the back plate of the metal combustion chamber

To produce the back plate of the metal combustion chamber, cut a piece of 1.5 mm mild steel with dimensions:

Width (F30): 337
Height (F31): 608.5

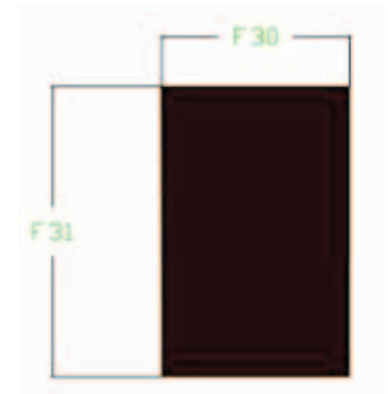

Figure 4.5: Dimension of the back plate of the combustion chamber

4d. Weld the three separate pieces together as shown in Figure 4.6 to create the metal combustion chamber.

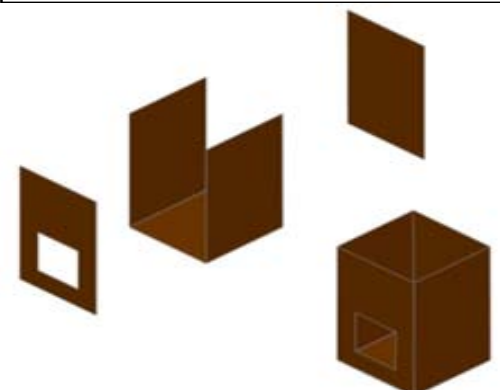

Figure 4.6: mild steel sheet sections welded together to form the metal combustion chamber

5 PREPARE THE COMBUSTION CHAMBER LINER.

Please refer to the Appendix A of this manual for detailed dimensions of the different moulds.

The appendix A provides the size of the metal moulds that should be constructed to produce the proper **post fired** dimensions of the ceramic tiles. The combustion chamber is made up of nine separate sections.

If you are producing the ceramic liner without a mould (e.g. you are cutting pre-fired ceramic or pumice blocks) then we assume you input '0' in the clay shrinkage field of the online tool. This manual will then provide the **exact** dimensions that are needed to produce each of the ceramic tiles.



These liners have beveled edges that when joined will form a miter joint. This is designed to prevent an **inward** collapse of the ceramic sections. The insulation that will be placed between the liners and the sheet metal cladding will prevent the liner from collapsing **outwards**. **Note:** some (but not all) pieces have beveled edges (see excel guide)

Figure 5.2 Assembly of the clay tiles that form the combustion chamber. See Appendix A and excel sheet for exact sizing information.

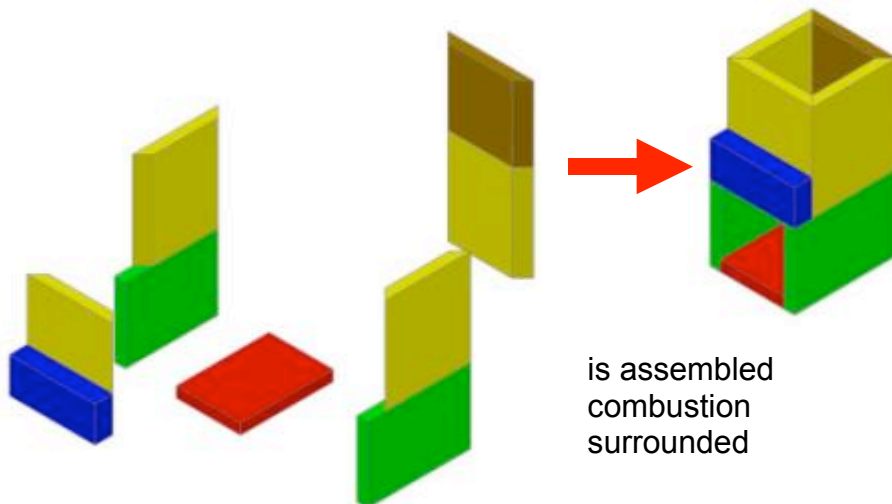

The combustion chamber is assembled inside the metal chamber box and with insulation.

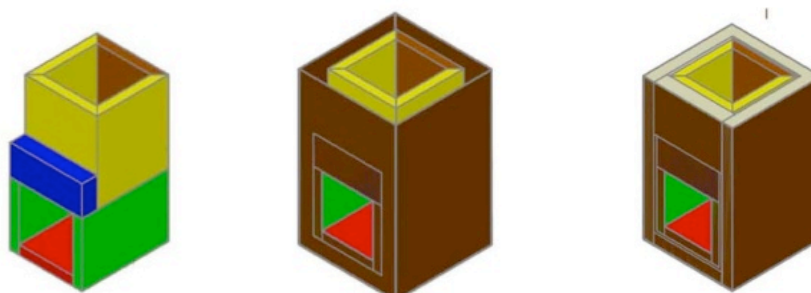

Place appropriate insulation on the floor of the metal chamber. Fit the pieces together as shown in the photos below. Make sure that the ceramic tiles are centered inside the chamber before filling with insulation.

Figure 5.3: Combustion Chamber Assembly

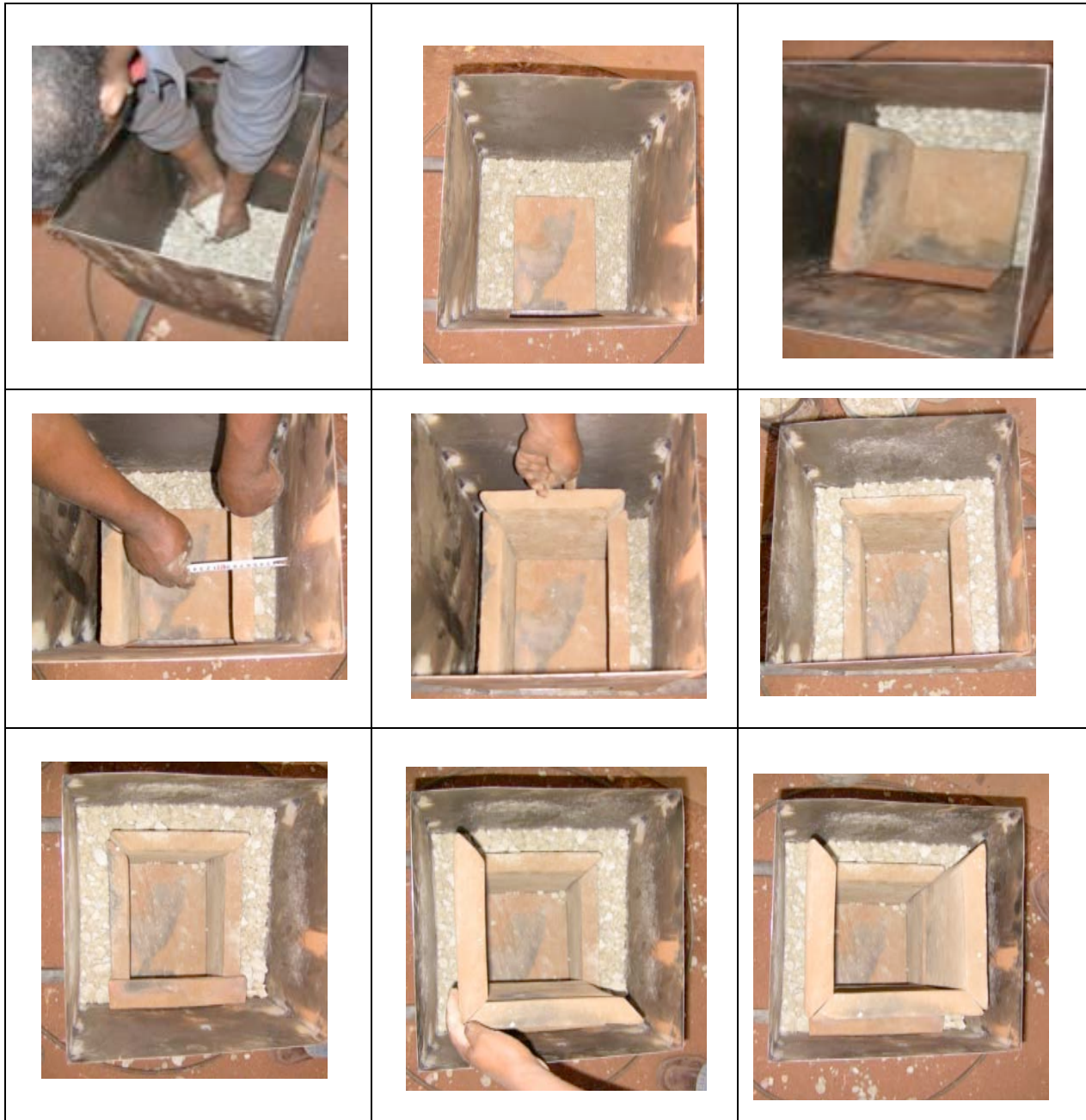

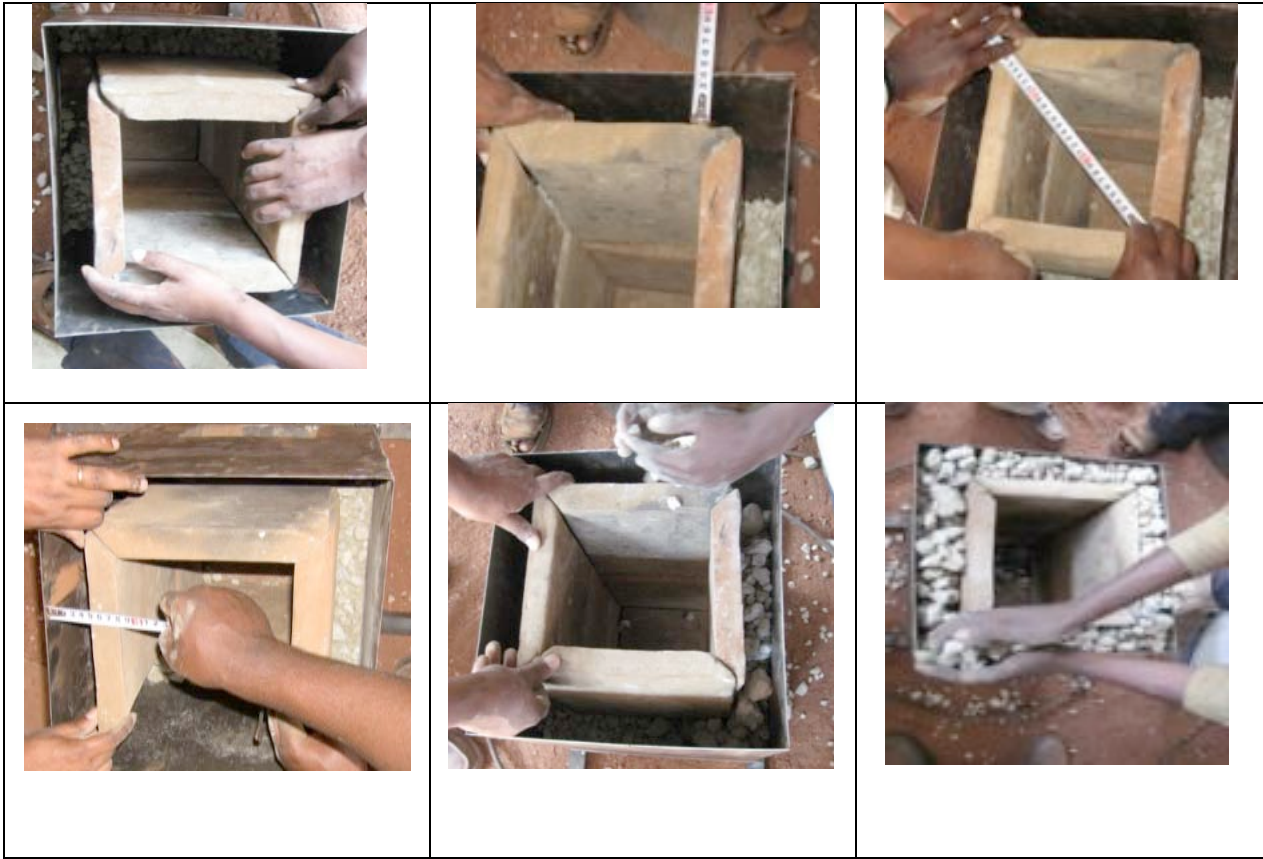

The assembled liner shown inside and outside of the metal combustion chamber box



6 PRODUCE THE STOVE BASE RING

Take a length of 12 mm round bar and cut a length of 2915

2915



Roll and hammer this into a perfect circle with an **outside** diameter of 952

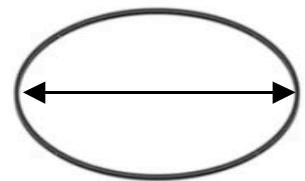

952

7 PREPARE THE LOWER ANGLE IRON SUPPORTS

Take a piece of 30 mm wide by 3 mm thick angle iron and cut two lengths equal to 870
These are angle iron 'A' and 'B'

870

Combustion chamber support long (2 in quantity)



Lay the two lengths of angle iron on level ground so that they make a reversed 'L' and a normal 'L' as shown in the drawing right. Then, place the base ring on top of the angle iron so that it fits into the 'crotch' of the angle iron. Weld.

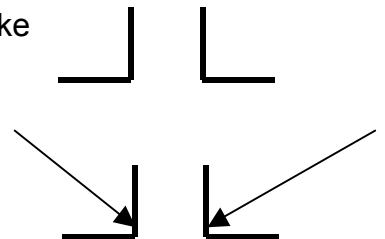

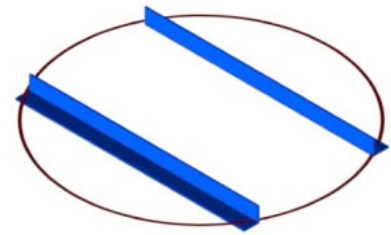

Angle iron pieces must be parallel

After welding, **flip** the base ring over so that it looks similar to the two drawings right.

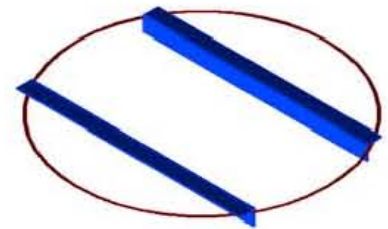
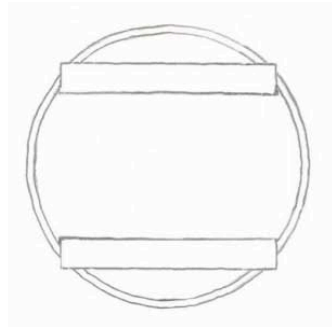

9 PREPARE THE UPPER ANGLE IRON SUPPORTS

Cut 2 additional pieces of angle iron in length of 340
These are angle iron 'C' and 'D'

Place these pieces face up (as shown in drawings below)

Place angle iron sections 'C' and 'D' on top of angle iron 'A' and 'B'.

The distance between 'C' and 'D' should be 338

These angle iron must also be placed parallel/equidistant from each other. Use a tack weld to hold the angle iron temporarily in place. Once you are certain that the combustion chamber will fit easily between angle iron 'C' and 'D', you can use a full seam weld.

Combustion chamber support
Short (2 in quantity)

340

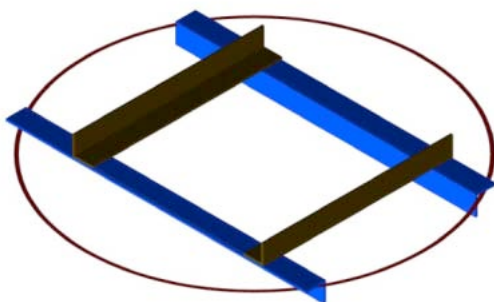
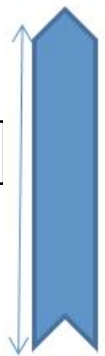

3/4 view

338

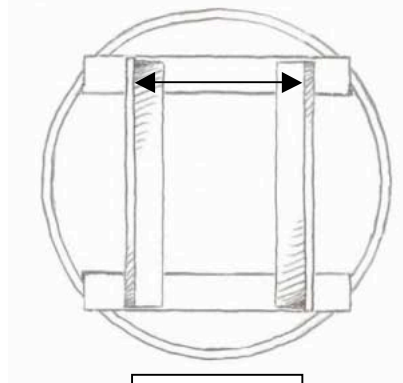

Top view



Front view

Confirm that the combustion chamber fits properly inside the angle iron sections but do **not** weld.



8 MAKING THE TOP PLATE

The top plate should be manufactured with 1.5mm sheet metal. At the center of the top plate there is an opening to the combustion chamber.

Figure 8.1 Dimensions of the top plate

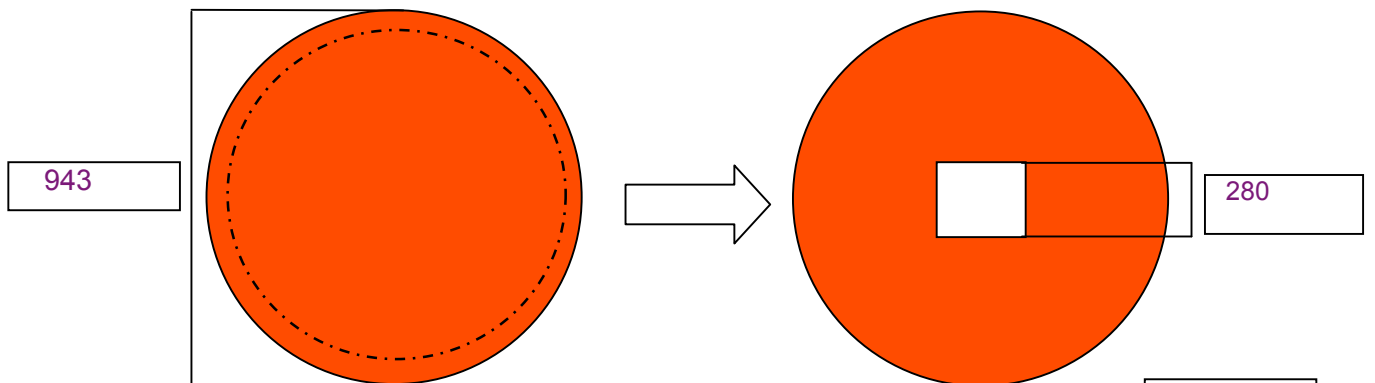
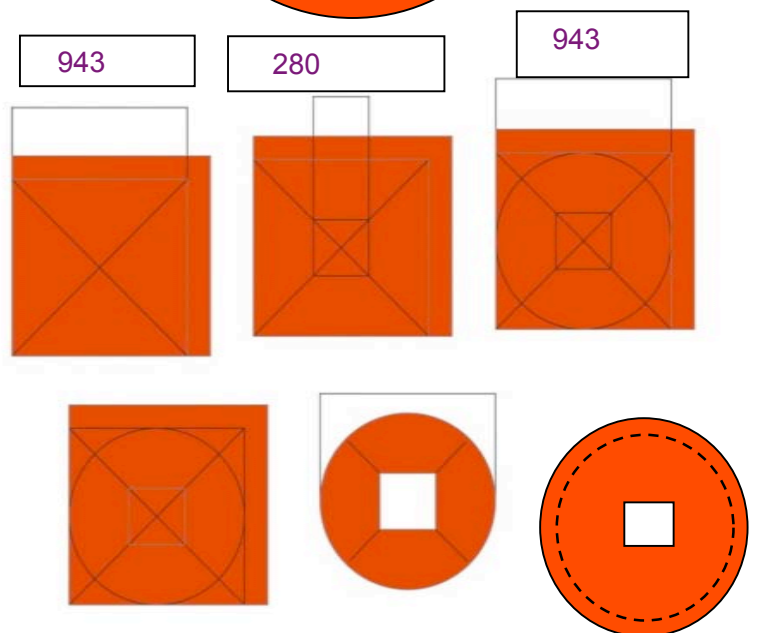

Plate diameter: 943
Plate opening: 280

As it is difficult to center an object within a circle it is preferable that the Top Plate opening should be scribed (but not cut!) **before** cutting the **circle**. Prepare the top plate in this order:

- Scribe the outer square
- Scribe the inner square
- Scribe the circle
- Cut the inner square



- Cut the outer circle
- Scribe a 50 mm circle inset from the outer edge



In other words, mark both the Top Plate **and** the Top Plate Opening before cutting. Do **not** weld the top plate to the combustion chamber

9 PREPARING THE STOVE SKIRTS

The CIRS has an inner skirt and an outer skirt. Between the two skirts, insulation will be placed to reduce the surface temperature of the outer skirt.

9.1 Produce the outer skirt

Figure 9.1: Dimensions of the outer skirt

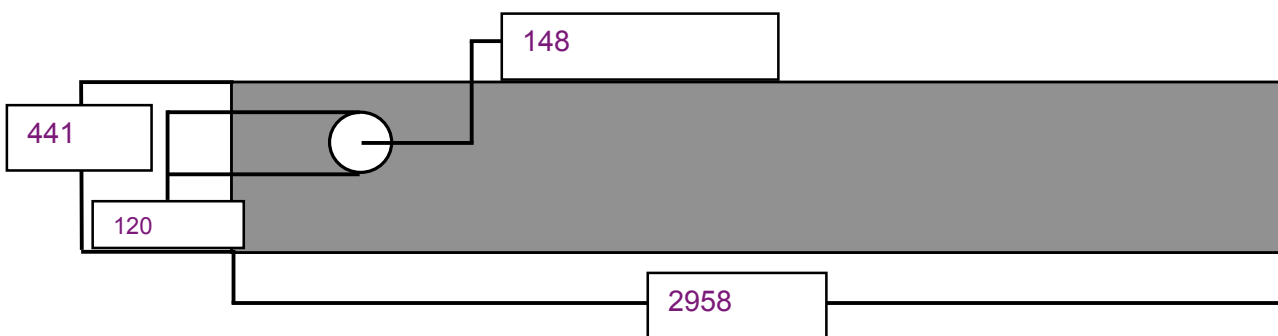

Use following dimensions to produce the outer skirt :

- Length/ circumference of outer skirt : 2958
- Height of the outer skirt : 441
- Distance from skirt top to chimney outlet center : 148
- Diameter of the chimney outlet : 120

.The chimney outlet should be centered 30 cm from the left edge of the skirt

After cutting out the opening, roll the section and tack weld the edges to make a perfect cylinder.

Check the diameter of the outer skirt: 942





Tack weld the outer skirt to the top plate. Make sure that the **chimney outlet** is directly behind the back wall of the combustion chamber.

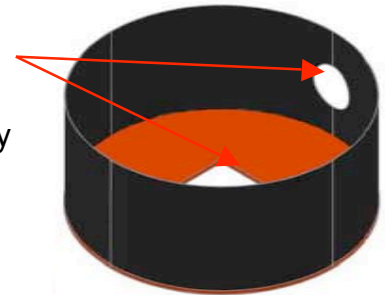

Place the welded top plate and outer skirt section on the metal combustion box

Make sure that the chimney outlet is directly opposite the fuel entrance before welding the outer skirt to the top plate.

Weld the **top plate** to the **combustion chamber** body. Make sure that:

- the combustion chamber sits **between and inside** the angle irons and is centered on all 4 sides
- the **outer perimeter** of the top plate is flush with the base ring
- the back of the combustion chamber is flush with the back of the angle iron 'C' and 'D'

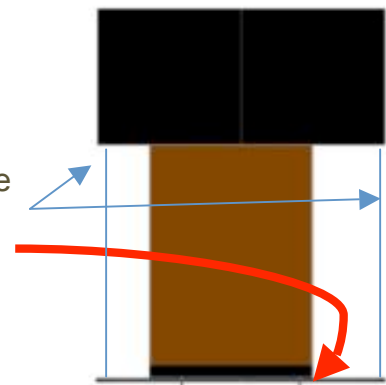

9.2 Produce the inner skirt

Figure 9.2: Use following dimensions for the inner skirt. In the drawing the dotted line represents the height of the top plate insulation (see Step 14 for details)

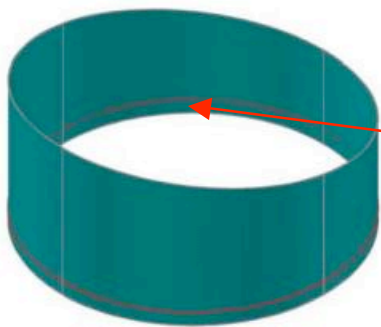
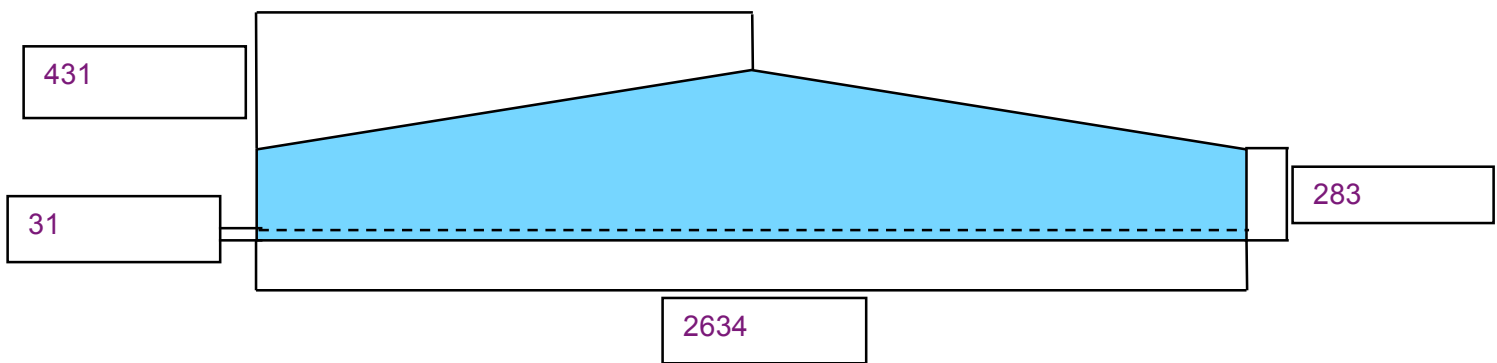

Figure 9.3: Inner skirt after completion

Once all dimensions are marked, cut and roll the section so that the dotted line is on the **inside** of the cylinder.

Weld and hammer the shape until a perfect cylinder is formed. Check the diameter of the inner skirt: **839**



9.3 Connect the inner skirt to the base plate

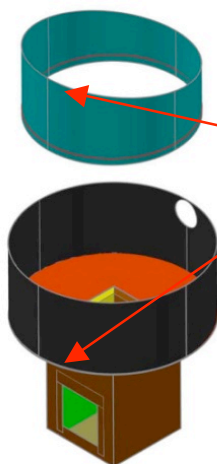

Place the inner skirt on the 50 mm inset line scribed in step 8.1 and tack weld.

The higher edge of the inner skirt must be placed directly above the fuel inlet.

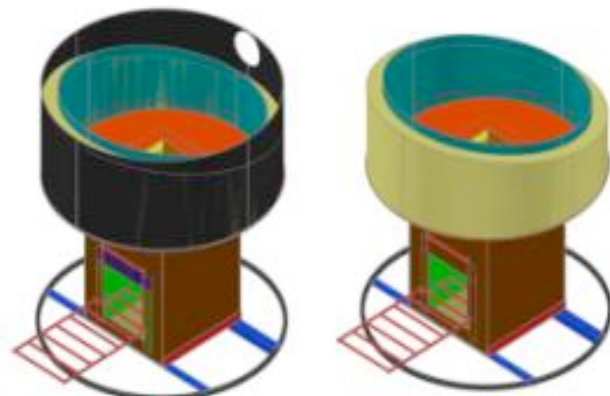



Pour the appropriate insulative material (such as loose pumice, loose vermiculite, or sawdust: clay (4:1 mixture) between the two skirts. The insulative material should be filled 5 cm **below** the top edge of the inner skirt.

10 POT STABILIZERS

Figure 10.1 Dimensions of the round bar used to produce

the pot stabilizer.

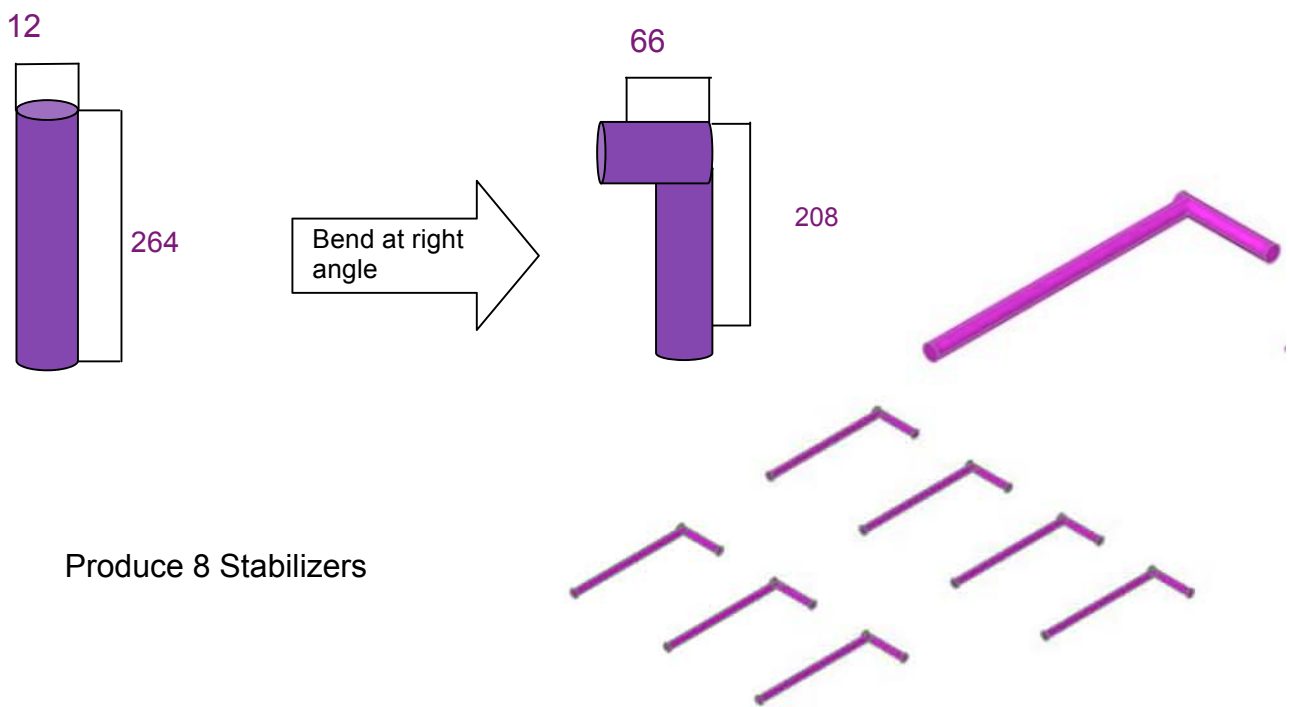

10a. Weld the stabilizers to the inner and outer skirt

The **top edge** of the stabilizer must be flush with the **top edge** of the outer skirt.

The **tip** of the horizontal section is welded to the **inside** of the outer skirt

The inner edge of the longer vertical section will be welded to the **inside** of the inner skirt

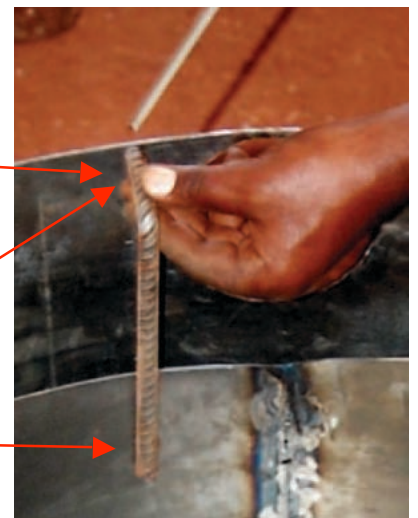

Place the stabilizers so they are equidistant from each other inside the stove. Weld the first four pot stabilizers at 12, 6, 3, and 9 o'clock. Weld the next four at 1:30, 7:30, 4:30, and 10:30

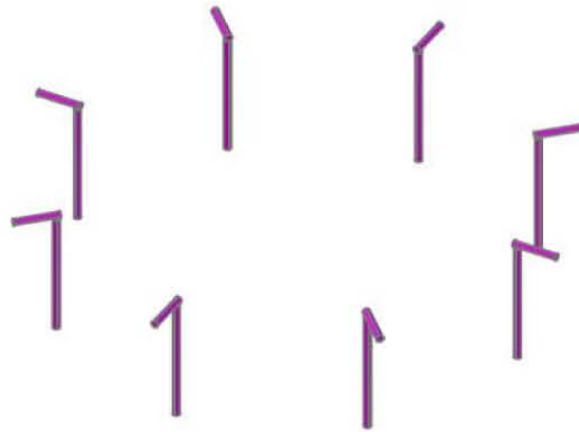
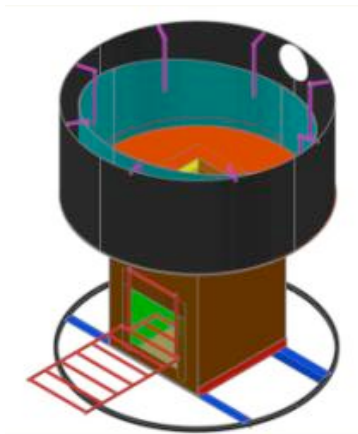

Figure 10.2 Weld the pot stabilizers to the skirt



8 pot stabilizers welded to the inner and outer skirt



11 MAKING THE TOP FLANGE

The top flange is used to cover the insulation gap between the skirts. It also creates a seal between the pot and the stove body which prevents smoke from leaking out of the stove.

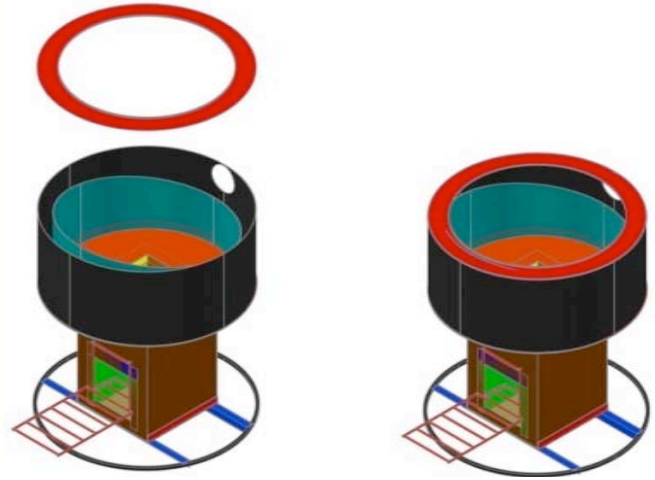

Figure 11.1 below shows the dimensions of the top flange.

Prepare the top flange in this order:

- Scribe the outer diameter : 943
- Scribe the inner diameter : 801
- Scribe the chamfer diameter : 811

calculate the dimensions of the top flange. The inner edge of the flange will be chamfered 5mm downwards **after** it is attached to the stove body.

811

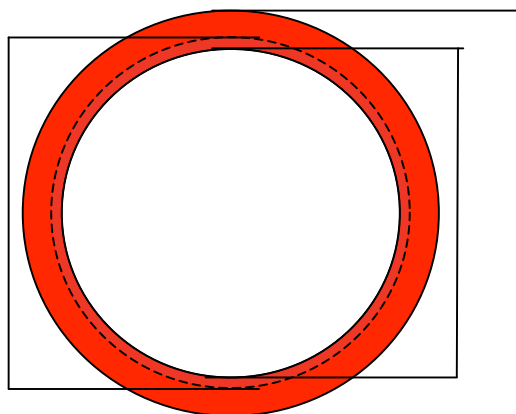

943

801

Flange with chamfered edge front view



Flange top view

Before welding the flange ensure that the gap between the inner and outer skirt is filled with insulation.

Place the flange on top of the pot stabilizers. Tack weld the outer edge of the top flange to the outside of the skirt.



To make the chamfered edge, highlight the 5 mm line on the inner edge of the flange. Chamfered circle diam.: 811



Using pliers, bend the inner edge of the flange downwards by approximately 20 degrees.

Continue bending in small increments until the fold is 45 degrees. When this is complete, use a hammer to fold to 90 degrees.

Continue to hammer the flange until the cooking pot can enter and exit the stove smoothly. The gap between the pot and the chamfered edge should be large enough for smooth insertion and removal of the pot but narrow enough to stop the smoke from escaping.



Completed views of the chamfered edge



12 MAKE THE STOVE LEGS

The stove has three legs that extend from the bottom of the top plate to the ground. The legs should be made from 40 mm by 40 mm (1.5-3 mm thick) square tube. Length of the legs: 643

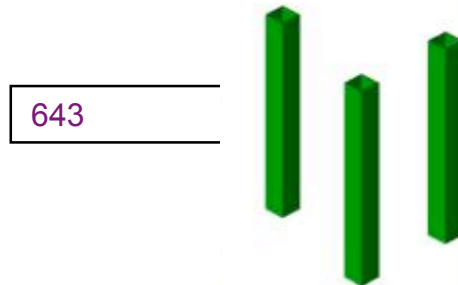

Take a length of square tube and cut 3 pieces.

The legs should be welded to:

- the **bottom** of the top plate, and
- to the **inside** of the base ring

Ideally the legs should be welded at the point where the **angle iron meets the base ring**. Place the three legs at 120, 240 and 360 degrees respectively. Be sure that the legs touch the ground to ensure a stable platform.

Ensure that the **bottoms** of the legs are flush with the **bottom** of the lower angle iron sections.

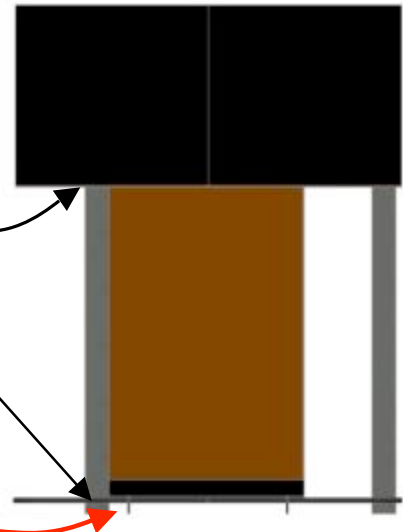

13 POT SUPPORTS

Three pot supports are needed. The legs should be made from 40mm by 40mm (1.5-3 mm thick) square tube. These pot supports shall be welded on the top plate with equal distance between them (i.e. at 0, 120 and 240 degrees).

Height of pot support : 53

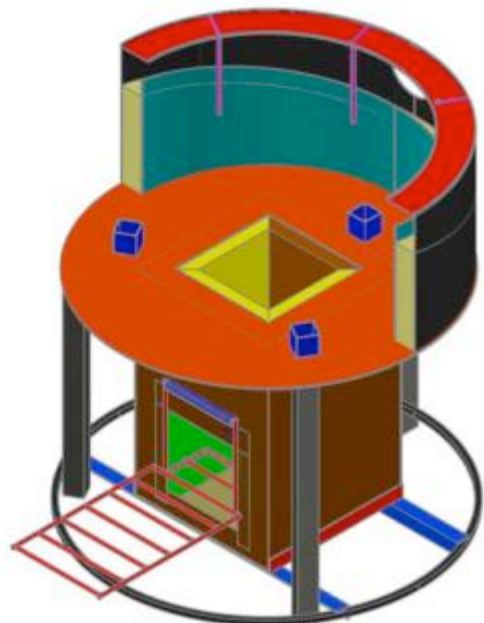

For additional reinforcement, a 2 mm thick pot support cap should be placed on top of the square tube to protect the bottom of the cooking pot.
Diameter of pot support cap: 6



14 INSULATING THE TOP PLATE

The top plate is insulated with a mixture of cement and insulative material such as pumice or vermiculite. The insulation on the top plate will provide the ideal profile for the optimal flow of hot flue gases under the cooking pot. It also protects the top plate from direct contact with the open flame. The insulation on the top plate slopes upward from the Inner Insulation lip out towards the **inner** edge of the **inner** skirt.

14a. Construct the Inner Insulation Lip

The **Inner Insulation Lip** will establish the thickness of insulation at the inner perimeter

Using 1.5 mm metal sheet, make a frame with following dimensions:

- Strip height: 12
- Strip length: 1128

Then fold the metal piece into a square with sides of 282

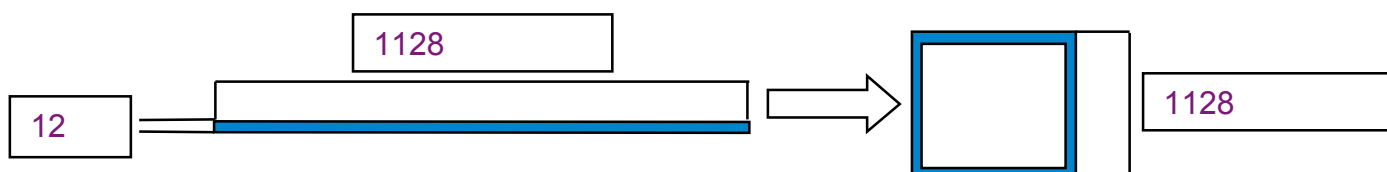

Weld this frame around the combustion chamber opening in the top plate. The height of the metal sheet will dictate the **thickness** of the insulation at the inner perimeter.



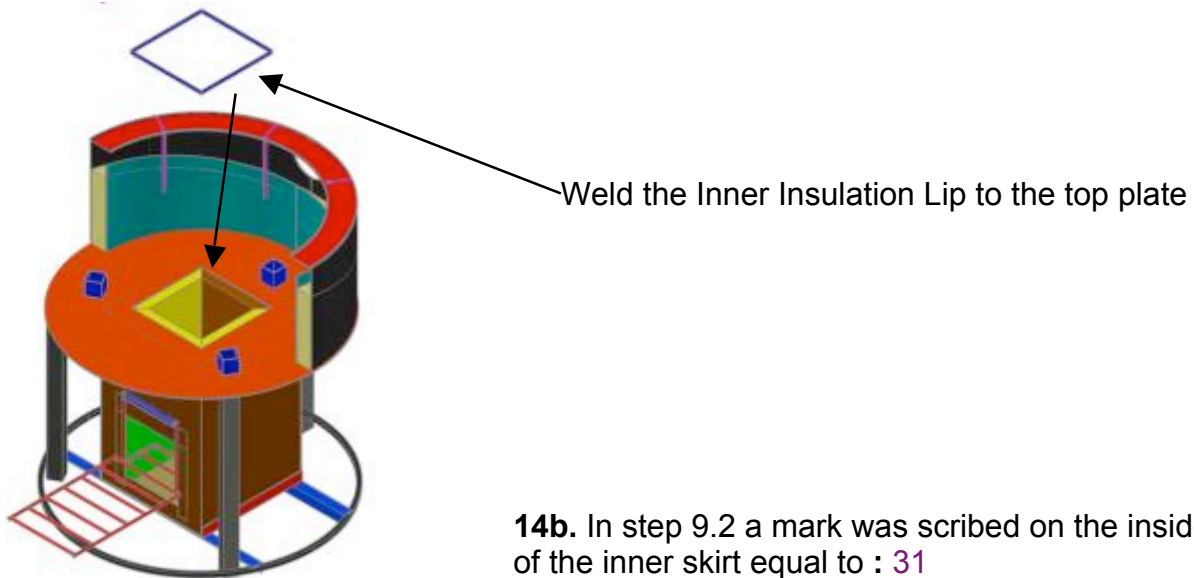

14b. In step 9.2 a mark was scribed on the inside of the inner skirt equal to : 31
Using chalk, highlight this mark a second time.



Height of slope at outer perimeter

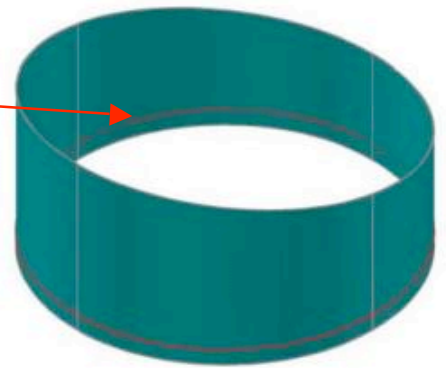

14c. Prepare the insulative mixture. Mix:

- 5 parts ground pumice (or other suitable insulative material)
- 1 part cement

*Other recipes are also possible. The idea is to create a low density (~0.5g/cc) durable mixture that will not degrade during normal cooking conditions. For example, in Ethiopia we are using a five-part pumice to 1 part cement mixture for insulating the top plate.

Fill this mixture on the top plate to produce a smooth slope between:

1. the **inner insulation lip** that was described in section 14a, and
2. the **chalk line on the inside of the skirt** that was marked in 14c



As the mixture covers the top plate, it will naturally create a slope upwards starting from the combustion chamber out towards the outer edge of the stove skirt.

Note: It is recommended to slightly **under fill** the slope to avoid inhibiting the airflow.



Figure 14.1 Diagrams showing the top plate insulation

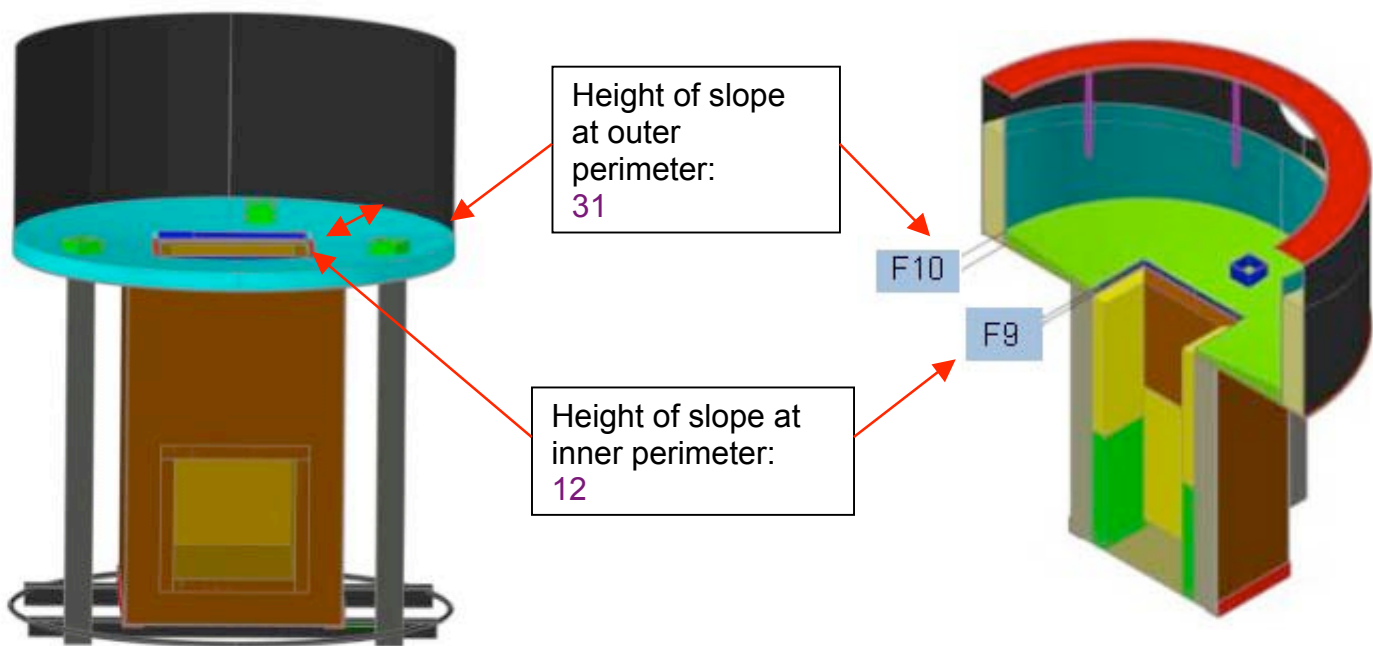

15 WOOD SUPPORT AND WOOD SHELF



The **Wood Support** should be manufactured using a 10 mm diameter round bar.

The **Wood Shelf** should be made with 10 mm diameter round bar.

The wood support is connected to the stove body via a **15 mm square hollow pipe** which allows the round bar skeleton



to enter freely and swivel. **Do not weld the wood support to the square hollow pipe.**

The following formula can be used to calculate the dimensions of the wood support and the wood shelf. The outer frame of the wood support should be made from one piece 10 mm round bar according to following dimension: 2023

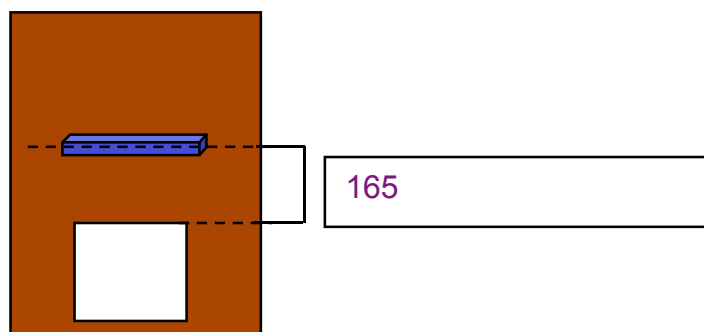
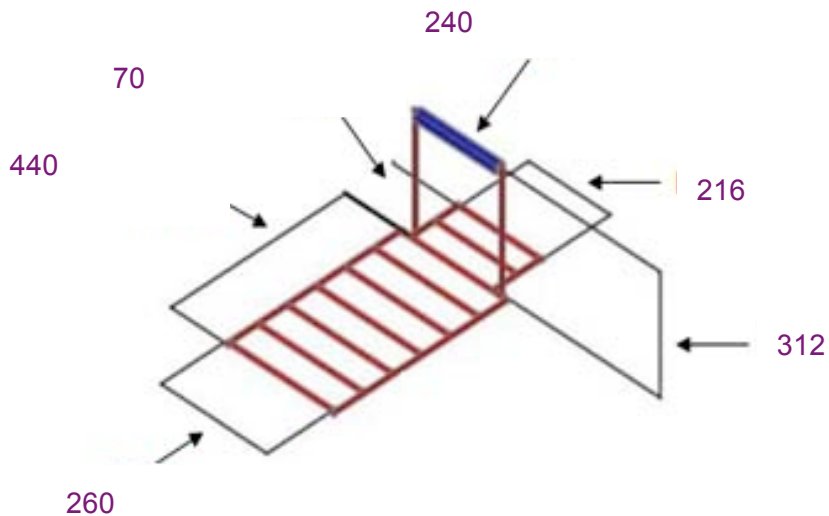

10 mm Round Bar Piece to Cut

- 1 Piece - Frame : 2023
- 4 Piece - Horizontal Frame Supports : 240
- 1 Piece Wood Shelf: 216 + 2 x 70 = 356
- 1 Piece Horizontal Wood Shelf Support: 196



16 PRODUCING THE CHIMNEY ELBOW (CHIMNEY INTERFACE)

The chimney elbow is attached to the outer skirt. It encloses the chimney outlet and supports the chimney riser.

Figure 16.1 Chimney interface

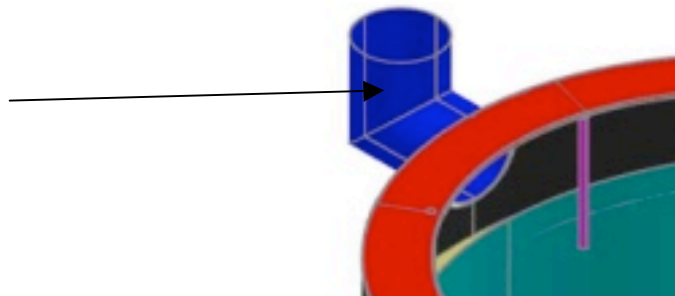

The chimney elbow can be manufactured using a sheet metal of 0.8 – 1.0 mm thickness. The internal diameter of the **chimney elbow** will be **2 mm wider** than the internal diameter of the **chimney outlet**. Here are the dimensions of the metal sheet for making the chimney interface:

Width: 394
 Length: 394
 Diameter: 126

Figure 16.2: Preparation of the chimney interface

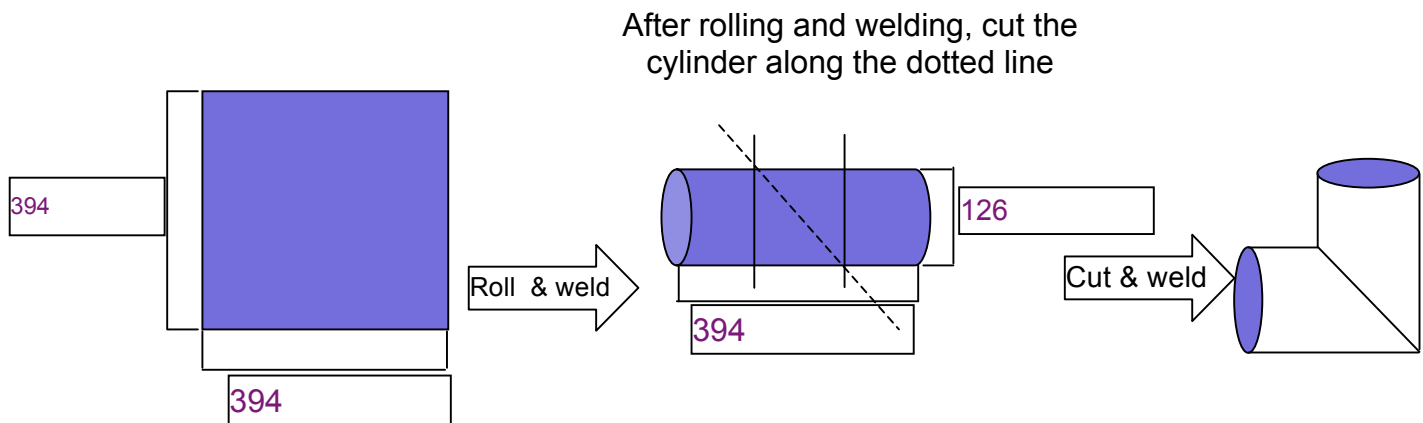

After cutting out the sheet metal section as indicated in Figure 16.2, roll and weld the two edges. Mark the cylinder with rings at exactly one third of its length from both ends. Cut the cylinder at 45° starting from one of the rings marked on the cylinder. Transpose one of the cut pieces and weld it to the other pieces. This will give a 90° elbow to connect to the chimney riser.

17 PRODUCING THE CHIMNEY RISER

The chimney should be at least 3 m tall. Ideally the chimney should extend above the peak of the roof but this is not always feasible.

Produce three chimney risers. Each of the risers is one meter in length. The first riser (which has a slightly larger radius than the chimney elbow) will fit on the outside of the chimney interface/ elbow. The second riser (which has a slightly larger radius than the first) will fit on the outside of the first riser. The third riser (which has a slightly larger radius than the second) will fit on the outside of the second riser.

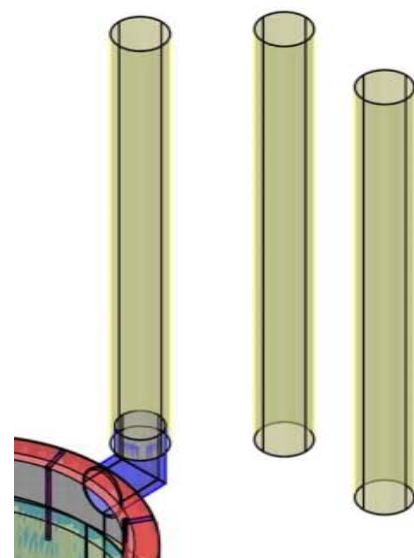

The chimney pieces can be cut from a piece of galvanized sheet metal of 0.6mm thickness and one meter in length.

- | | | | | |
|-------------------------|------------|-----|--------|-----|
| 1. Bottom chimney piece | Diameter : | 130 | Width: | 427 |
| 2. Middle chimney piece | Diameter : | 134 | Width: | 439 |
| 3. Upper chimney piece | Diameter : | 138 | Width: | 452 |

Cut the chimney pieces from the galvanized sheet metal with their width indicated above. After cutting the sheet metal, seam the edges using 5mm width of the sheet metal on each side.

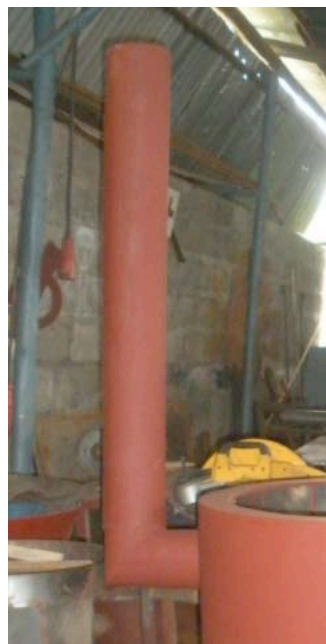
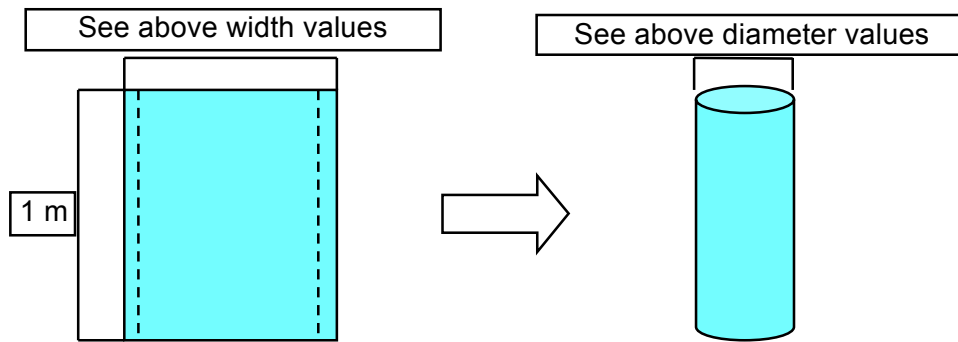

APPENDIX A: COMBUSTION CHAMBER MOLDS

The combustion chamber is made from 9 ceramic tiles. These tiles are made from 5 metal molds. The mold dimensions will be **larger** than the final fired dimensions of the tiles to accommodate for the clay shrinkage. The shrinkage percentage of the local clay **must** be calculated independently by the user. The user should work with a local potter who has experience in making ceramics that can withstand abrasion and high temperatures (1000°C)

The pieces fit together as illustrated below:

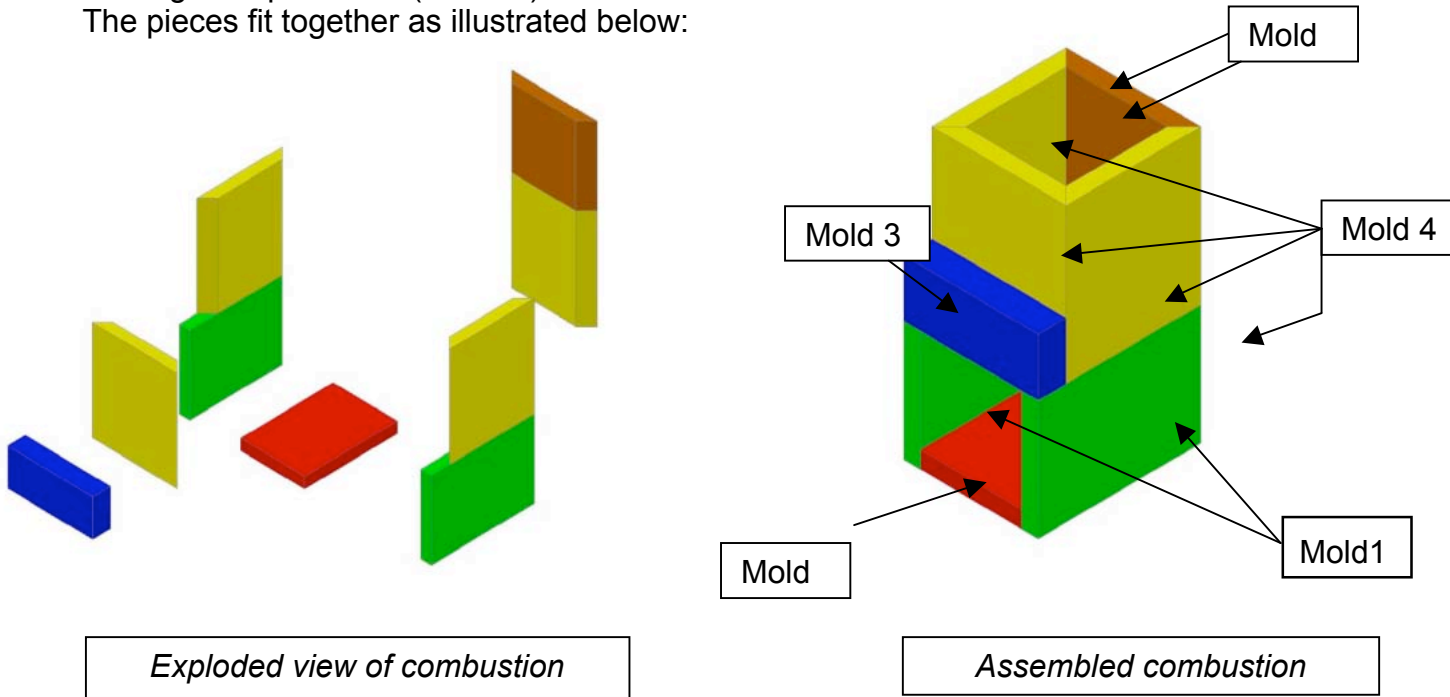

Mold No. 1: Bottom floor of the combustion chamber

Top View

Cross section (A-A)

Cross section (B-B)

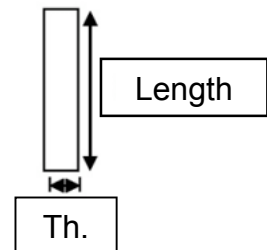
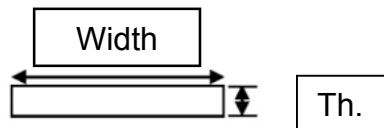
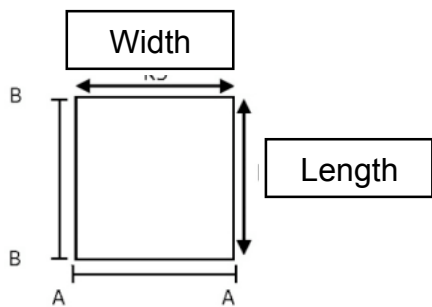

Width: 239
 Length : 304
 Thickness (Th.) : 30



Mold No.2: Bottom side walls of the combustion chamber

Top View

Cross section (A-A)

Cross section (B-B)

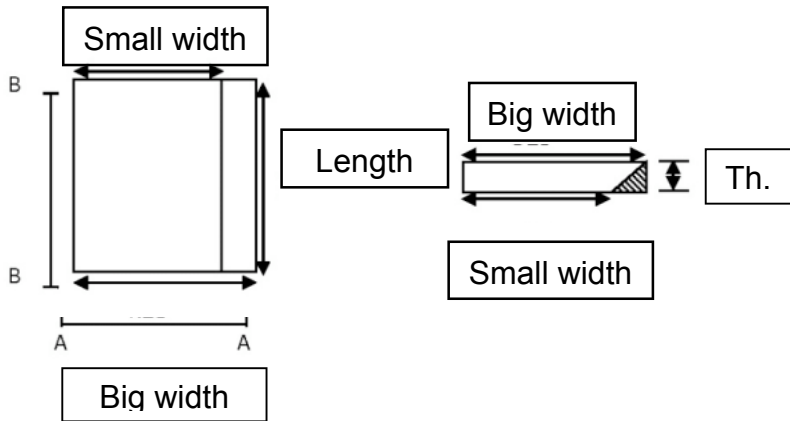

Small width: 307
 Big width : 337
 Length : 272
 Thickness (Th.) : 30

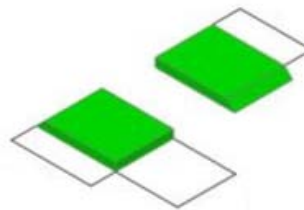

Mold No.3: Top horizontal wall

Top View

Cross section (A-A)

Cross section (B-B)

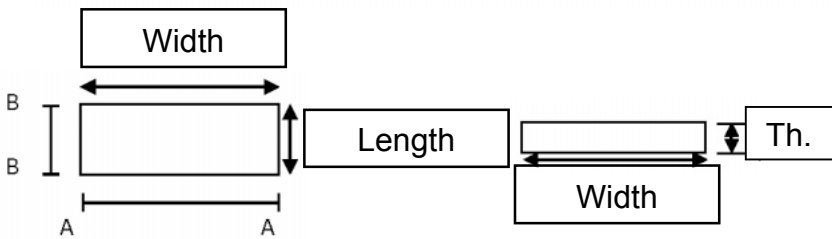

Width: 304
 Length : 33
 Thickness (Th.) : 30

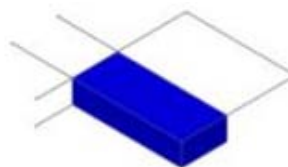

Mold No.4:

Top front and side walls and back bottom wall of the combustion chamber

Top View

Cross section (A-A)

Cross section (B-B)

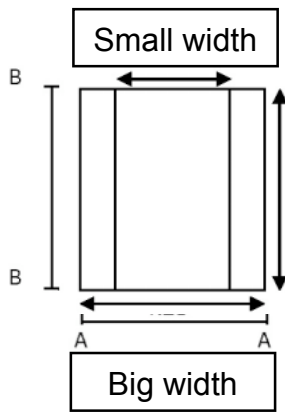

Length

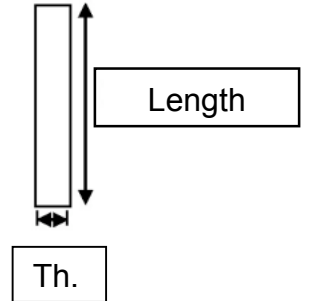
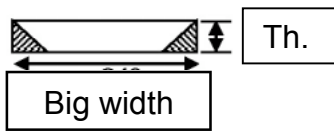

- Small width: 244
- Big width : 304
- Length : 359
- Thickness (Th.) : 30

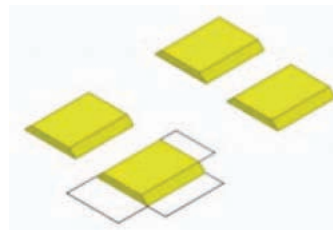

Mold No.5:

Back top wall of the combustion chamber

Top View

Cross section (A-A)

Cross section (B-B)

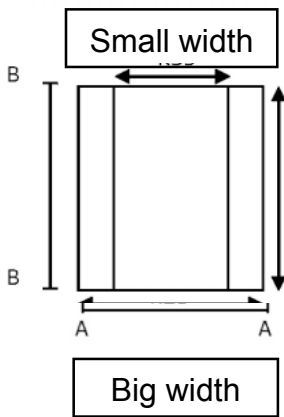

Length

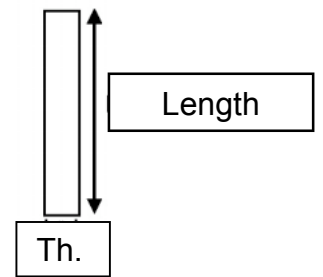
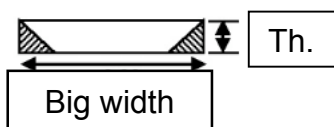

- Small width: 244
- Big width : 304
- Length : 272
- Thickness (Th.) : 30

